

QUADRO LED VII (RE-EDITION 2014)

Design Jacques Adnet, 1929/2014

Lampada da tavolo icona della collezione Classic LCI disegnata nel 1929 da Jacques Adnet esponente di spicco del Modernismo francese e, in quegli anni, direttore de "La Compagnie des Arts Francais" in cui operarono Francois Jourdain, Charlotte Perriand e Georges Jouve. QUADRO, da sempre a catalogo LCI, fu realizzata su decisione dell'allora direttore artistico Gilles Derain, tra i primi estimatori e studiosi dei movimenti modernisti francesi. La lampada è realizzata in tubolare d'ottone con placcatura elettrolitica in Palladio o in Oro Zecchino. Diffusori in resina acrilica sabbata. Base in marmo nero Marquina e marmo bianco di Carrara, cavo elettrico in tessuto nero. Pulsante di accensione con regolatore di intensità luminosa. Sorgenti luminose LED integrate.

Table lamp, icon of the Classic Collection LCI, designed in 1929 by Jacques Adnet great exponent of French Modernism and director of the "La Compagnie des Arts Francais" where Francois Jourdain, Charlotte Perriand and Georges Jouve also served. QUADRO, since ever in LCI catalogue, was built upon a decision by Gilles Derain, LCI Art Director at that time and one of the French modernist movements estimators. The lamp is made with a tube shaped structure in brass with electrolytic plating in Palladium or Gold. Diffusers in sand acrylic resin. Base in black Marquina marble or white Carrara marble and electric cable in black fabric. Dimmable power-button. Embedded LED light sources.

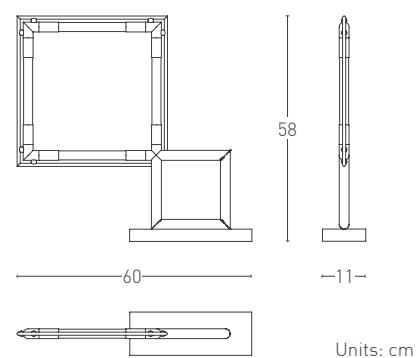

Finishes

- 160 Palladium + ● Black Marquina
- 154 Gold + ○ White Carrara

Diffuser

RA acrylic resin

Cable

Black fabric

Electronic driver

Dimmable included

Light source

LED

LED 110/240V 8x2W
2000lm 2700K CRI>90

A

Certification

CE EAC PS E F IP20

